

Detail of Side bracket (S=1/6)

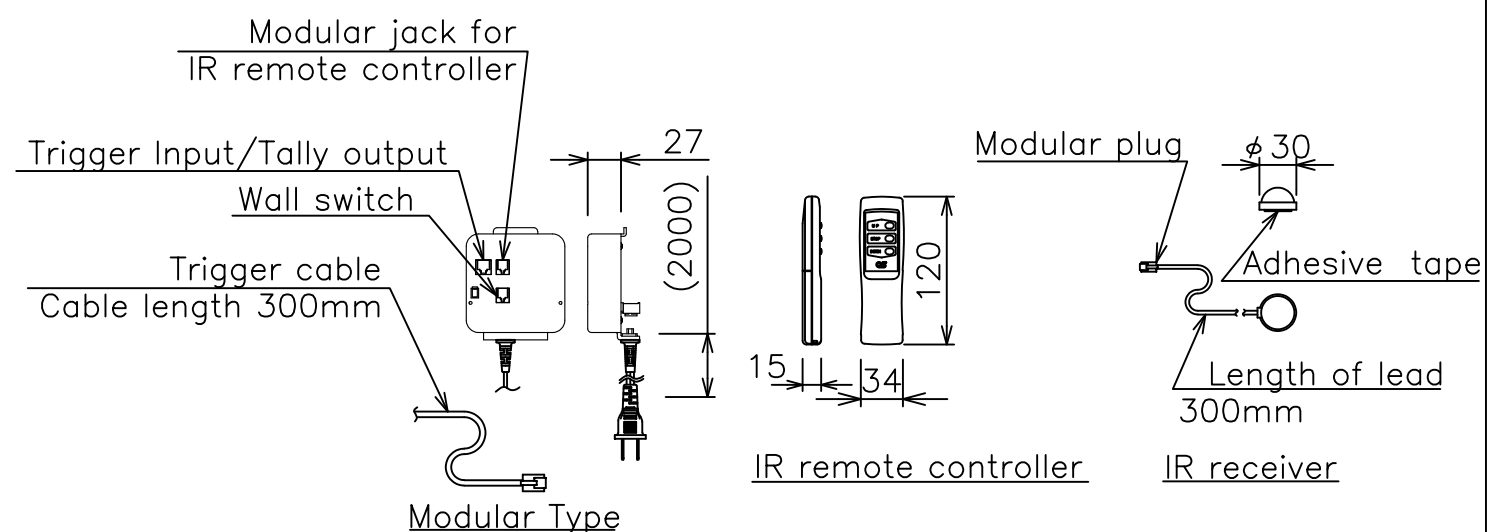

Circuit box and control switch(S=1/6)

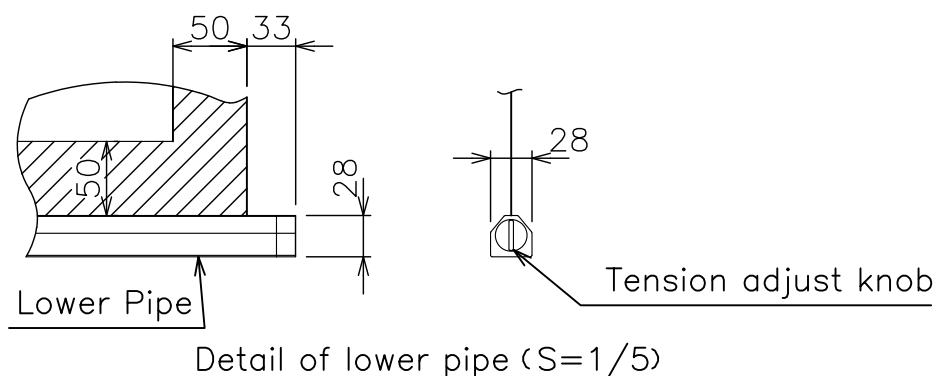

Detail of lower pipe (S=1/5)

**Note**

- The switch box, the primary and secondary electric wirings, plumbings and wiring materials are required separately.
- The reception sensitivity may decrease and IR range may be shortend under the inverter lighting.
- External dimensions are rounded up after the decimal point.
- \* Size shown is with side bracket.

Motor	Built in roller type
Voltage	AC100~120V 50/60Hz
Current	0.96A
Motor rated operation time	4min
Control voltage	DC5V
Travel speed	50Hz: 67 · 60Hz: 80 (mm/sec)

Screen materials	Pure MatⅢ Cinema (WF302)
Screen case	Material: Aluminium Color: White
Front panel	Material: Aluminium Color: Black Detachable
Mechanism	IR remote controller
Weight	32.6kg
Aspect ratio	HDtype(16 : 9)