

SEL

【Material lineup】
WG207

ASPECT RATIO
16:10

Flame retardancy

LARGE PROJECTION SCREEN

elec

Using a large size roller which requires no special adjustment mechanism, and offering high flatness.

The motor fits inside the pipe, large screen with built-in motor.

- Motor with upper limit function is installed in the roller.
- Uses large roller to ensure flatness.
- Push button type limit switch is adopted.
- Aluminum top plate is adopted in order to cope with setting on slabs and hanging rack.



[Dimensional drawing]

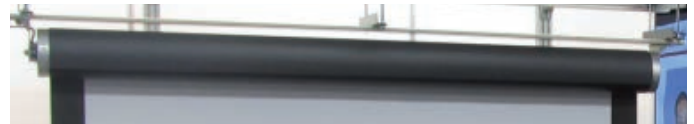
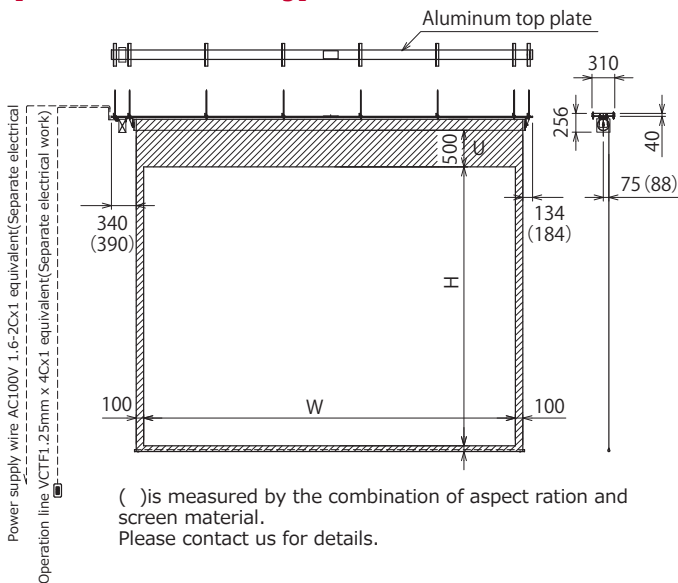

■ Aluminum top panel is equipped as standard

[WXGA 16:10]

Diagonal size (inch)	Model	Image size WxH (mm)	UBB U (mm)
226	SEL-220W	4871×3045	500
257	SEL-250W	5535×3460	500
278	SEL-270W	5977×3736	500

[Material lineup]

Diagonal size (inch)	Model	Applicable screen materials
226	SEL-220W	WG207
257	SEL-250W	WG207
278	SEL-270W	WG207

(SEL is completely made to order. Please contact our sales to quote.)

Sold by

OSI CO., LTD.



20th Floor, Wah Hing Commercial Building, 283 Lockhart Road, Wanchai, Hong Kong

Tel.+852-3580-0087 Fax.+852-2367-4300

<https://hk.os-worldwide.com/> info-hk@os-worldwide.com