

Large projection screen



EB

【Material lineup】
WG207

Original retention mechanism for flatness. Offering easy installation and safety. Large projection screen

- The burden of loading and mounting is reduced by split of motor, relay and roller parts.
- Equipped with a safety function that stops operation immediately even if the switch cable is cut off during ascent and descent.
- Applicable to upward motor type also.
- When mounting on a hanging rack..etc, it is also possible to respond to special custom made rack mount brackets.



[Dimensional drawing]

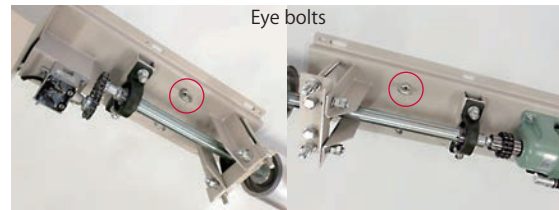
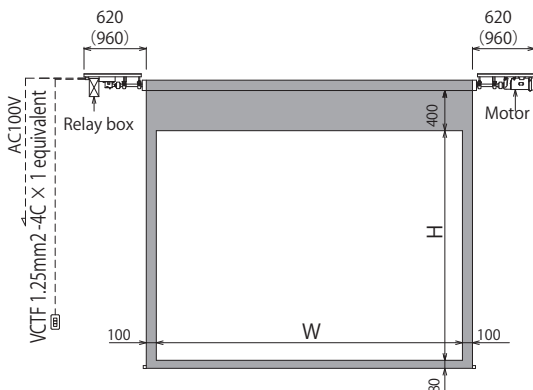

Eye bolts are standard equipment on the motor base and relay base. Pulleys can be used when hanging. A slot is adopted for temporal tacking of the base. Position adjustment is easy.

[WXGA 16:10]

Diagonal size(inch)	Model	Image size WxH(mm)	UBB U(mm)	Weight (Kg)
220	EB-200H	4428×2491	400	50.0
250	EB-250H	5535×3113	400	58.0
300	EB-300H	6642×3736	400	98.0

[Material lineup]

Diagonal size(inch)	Model	Applicable screen materials
220	EB-200H	WG207
250	EB-250H	WG207
300	EB-300H	WG207

Adjustment of motor position

It's adjustable the position of motor upward or downward in consideration of appearance and installation space.

■ Downward setting(Standard)

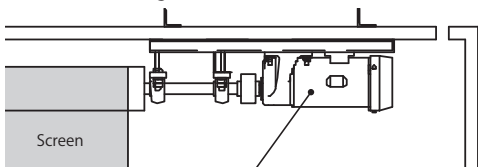

■ Upward setting

