

Fixed frame projection screen



STF

【Material lineup】
WV901

Fixed frame projection screen STF comes with high flatness.

The screen is available in two lineups as diffusive type and sound screen.

- High flatness and easy installation is available by adopting a spring fixed type.
- The spring flexibly responds to changes in the screen material environment due to temperature and humidity.
- Premium flocky is used on the frame surface.
- Easy to carry and assemble on site.
- High flatness screen is ideal for ultra short throw projectors.
- The screen is available in two lineups as diffusive type and sound screen.



[Dimensional drawing]

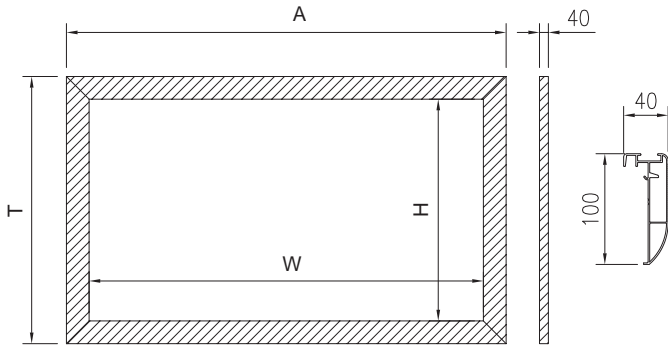

Flocky processed frame surface



Flexible springs are easily installed

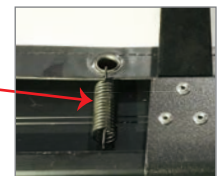

Hook for hanging spring

[WXGA 16:10]

Diagonal size(inch)	Model	Image size WxH(mm)	Length A(mm)	Height T(mm)	Depth B(mm)	Weight (Kg)
80	STF-080W-02	1723×1077	1927	1281	40	9.7
90	STF-090W-02	1939×1211	2143	1415	40	10.7
100	STF-100W-02	2154×1345	2358	1550	40	11.7
110	STF-110W-02	2369×1481	2573	1685	40	12.8
120	STF-120W-02	2585×1615	2789	1819	40	13.8
130	STF-130W-02	2800×1750	3004	1954	40	14.9
140	STF-140W-02	3015×1885	3219	2089	40	15.9
150	STF-150W-02	3231×2019	3435	2223	40	18.0
170	STF-170W-02	3662×2288	3866	2492	40	20.0
200	STF-200W-02	4308×2692	4512	2896	40	23.1

[Material lineup]

Diagonal size(inch)	Model	Applicable screen materials
80	STF-080W-02	WV901
90	STF-090W-02	WV901
100	STF-100W-02	WV901
110	STF-110W-02	WV901
120	STF-120W-02	WV901
130	STF-130W-02	WV901
140	STF-140W-02	WV901
150	STF-150W-02	WV901
170	STF-170W-02	WV901
200	STF-200W-02	WV901