

## P selection electric screen



# SEP

【Material lineup】  
WF801 WG207



Ⓒ Flame retardancy

The electric projection screen with simple design is not required any installation environment at various business scene.

Lineup of WF801, 4K flame retardant screen.

Compatible to 200 inches large screen.

- The simple panel design matches your interiors!
- Easy to know the center position as the case and fabric are symmetric design.
- Sliding bracket and side bracket are standard accessories.
- The front panel is detachable and exchangeable even after installation.
- Two choices of panel color-black or white.
- Lineup of WF801 with flame retardant, 4K compatible screen.

### [Dimensional drawing]

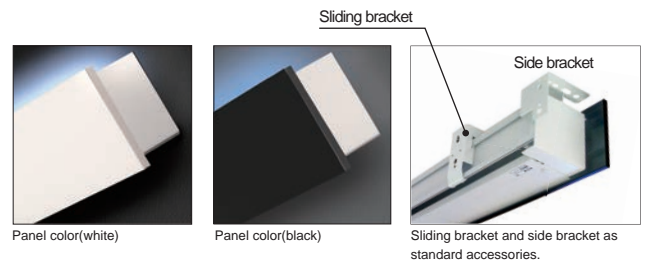
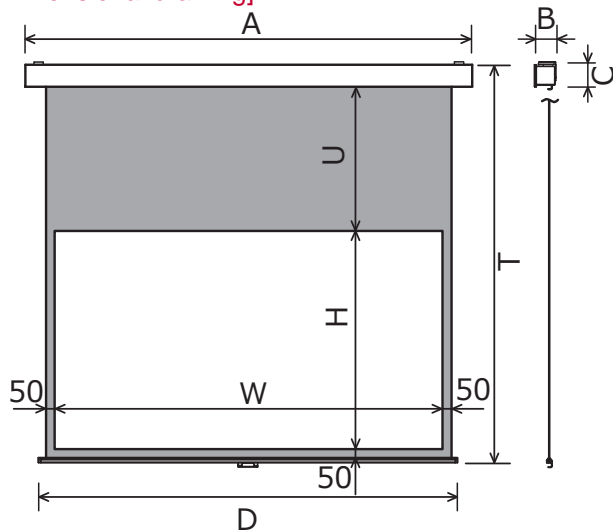

### [WXGA 16:10]

Diagonal size(inch)	Model	Image size WxH(mm)	Length A(mm)	Height T(mm)	UBB U(mm)	Side mask (mm)	Depth B(mm)	Height when in stored C(mm)	Pipe length D(mm)	Weight (Kg)
82	SEP-080WM-K1B	1771x1107	2111	1820	493	50	122	142	1937	11.4
92	SEP-090WM-K1B	1992x1245	2332	1820	355	50	122	142	2158	12.4
102	SEP-100WM-K1B	2214x1384	2554	2270	666	50	122	142	2380	13.7
113	SEP-110WM-K1B	2435x1522	2775	2270	528	50	122	142	2601	14.7
123	SEP-120WM-K1B	2657x1661	2997	2270	389	50	122	142	2823	15.6
133	SEP-130WM-K1B	2878x1799	3225	2529	500	50	134	152	3044	19.7
143	SEP-140WM-K1B	3099x1937	3446	2667	500	50	134	152	3265	21.0
154	SEP-150WM-K1B	3321x2076	3668	2806	500	50	134	152	3487	22.3
174	SEP-170WM-K1B	3764x2353	4111	3101	500	50	155	170	3930	39.5
205	SEP-200WM-K1B	4428x2768	4835	3546	500	50	155	170	4654	46.7

### [Material lineup]

Diagonal size(inch)	Model	Applicable screen materials
82	SEP-080WM-K1B	WF801
92	SEP-090WM-K1B	WF801
102	SEP-100WM-K1B	WF801
113	SEP-110WM-K1B	WF801
123	SEP-120WM-K1B	WF801
133	SEP-130WM-K1B	WF801
143	SEP-140WM-K1B	WF801
154	SEP-150WM-K1B	WG207
174	SEP-170WM-K1B	WG207
205	SEP-200WM-K1B	WG207