

Tab tension projection screen



SEG

【Material lineup】

WF204

WV901

WS901

WS902

Electric projection screen with excellent cost performance.

Available with diffusive type screen material(WF204, WV901) and Sound screen(WS901/902)

- Tab tension mechanism provides high flatness.
- Available for 80" ~ 150" .
- Two types are available : Diffusive type and sound screen.



[Dimensional drawing]

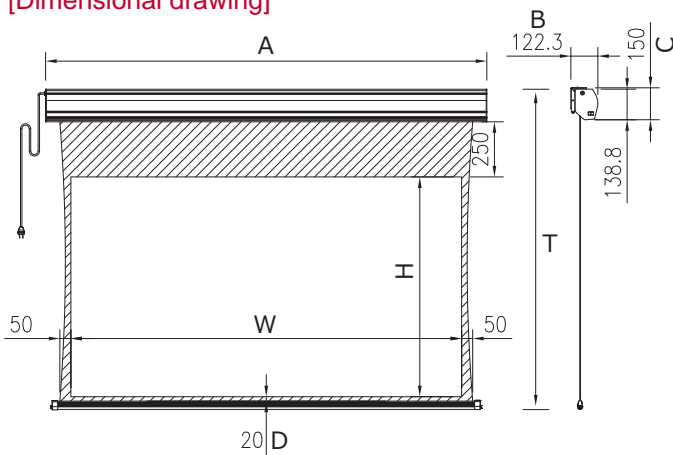

[HD 16:9]

Diagonal size(inch)	Model	Image size WxH(mm)	Length A(mm)	Height T(mm)	UBB U(mm)	Depth B (mm)	Height when in stored C(mm)	Pipe length D(mm)	Weight (Kg)
80	SEG-80HM-W1A	1771×996	2000	1416	250	122.3	150	20	15
90	SEG-90HM-W1A	1992×1121	2221	1541					17
100	SEG-100HM-W1A	2214×1245	2443	1665					18
110	SEG-110HM-W1A	2435×1370	2664	1790					20
120	SEG-120HM-W1A	2656×1494	2885	1914					21
130	SEG-130HM-W1A	2878×1619	3107	2039					23
140	SEG-140HM-W1A	3099×1743	3328	2163					24
150	SEG-150HM-W1A	3321×1868	3550	2288					26

[Material lineup]

Diagonal size(inch)	Model	Applicable screen materials
80	SEP-080HM-W1A	WF204 WV901 WS901 WS902
90	SEP-090HM-W1A	WF204 WV901 WS901 WS902
100	SEP-100HM-W1A	WF204 WV901 WS901 WS902
110	SEP-110HM-W1A	WF204 WV901 WS901 WS902
120	SEP-120HM-W1A	WF204 WV901 WS901 WS902
130	SEP-130HM-W1A	WF204 WV901 WS901 WS902
140	SEP-140HM-W1A	WF204 WV901 WS901 WS902
150	SEP-150HM-W1A	WV901 WS901 WS902