

Fixed frame projection screen



STF

【Material lineup】

WV901 WS901 WS902

Fixed frame projection screen STF comes with high flatness.

The screen is available in three lineups as diffusive type and sound screen.

- High flatness and easy installation is available by adopting a spring fixed type.
- The spring flexibly responds to changes in the screen material environment due to temperature and humidity.
- Premium flocky is used on the frame surface.
- Easy to carry and assemble on site.
- High flatness screen is ideal for ultra short throw projectors.
- The screen is available in three lineups as diffusive type and sound screen.



[Dimensional drawing]

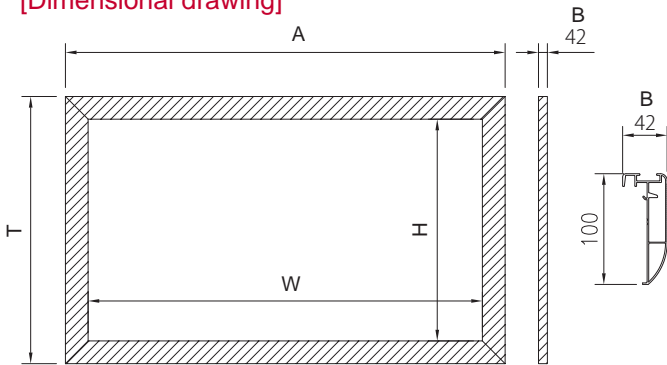

Flocky processed frame surface

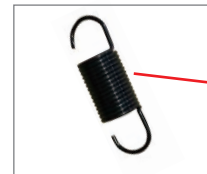

Flexible springs are easily installed

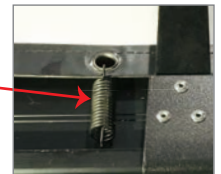

Hook for hanging spring

[HD 16:9]

Diagonal size(inch)	Model	Image size WxH(mm)	Length A(mm)	Height T(mm)	Depth B(mm)
80	STF-080H-A	1771×996	1975	1211	42
90	STF-090H-A	1992×1121	2196	1336	42
100	STF-100H-A	2214×1245	2418	1460	42
110	STF-110H-A	2435×1370	2639	1585	42
120	STF-120H-A	2656×1494	2860	1709	42
130	STF-130H-A	2878×1619	3082	1834	42
140	STF-140H-A	3099×1743	3303	1958	42
150	STF-150H-A	3321×1868	3525	2083	42
170	STF-170H-A	3764×2117	3968	2332	42
200	STF-200H-A	4428×2491	4632	2706	42

[Material lineup]

Diagonal size(inch)	Model	Applicable screen materials
80	STF-080H-A	WV901 WS901 WS902
90	STF-090H-A	WV901 WS901 WS902
100	STF-100H-A	WV901 WS901 WS902
110	STF-110H-A	WV901 WS901 WS902
120	STF-120H-A	WV901 WS901 WS902
130	STF-130H-A	WV901 WS901 WS902
140	STF-140H-A	WV901 WS901 WS902
150	STF-150H-A	WV901 WS901 WS902
170	STF-170H-A	WV901 WS901 WS902
200	STF-200H-A	WV901 WS901 WS902

(NTSC (4:3), WXGA (16:10), Cinema Scope(2.35:1)are available on your request.)